

Uninterruptible Power Supply

ZY120



10-20kVA 3/1

User Manual

EMPTY PAGE

IMPORTANT SAFETY INSTRUCTIONS

SAVE THESE INSTRUCTIONS

This manual contains important safety instructions. Read all safety and operating instructions before operating the uninterruptible power systems (UPS). Adhere to all warnings on the unit and in this manual. Follow all operating and user instructions. This equipment can be operated by individuals without previous training.

This products designed for commercial/industrial use only. It is intended for use with lift support and other designated "critical" devices. Maximum load must not exceed that shown on the UPS rating label. The UPS is designed for data processing equipment. If uncertain, consult your dealer or local representative.

This UPS is designed for use on a properly grounded (earthed), 220/230/240VAC, 50 or 60Hz supply. The factory default setting is 230VAC/50Hz. Installation instructions and warning notices are in this manual.

The UPS 10/20@220/230/240VAC is designed for use with a five-wire input (L1, L2, L3, N, G).



WARNING

THE BATTERY CAN PRESENT A RISK OF ELECTRICAL SHOCK AND HIGH SHORT CIRCUIT CURRENT. FOLLOWING PRECAUTIONS SHOULD BE OBSERVED BEFORE REPLACING THE BATTERY.

- Wear rubber gloves and boots.
- Remove rings, watches and other metal objects.
- Use tools with insulated handles.
- Do not lay tools or other metal objects on the batteries.
- If the battery is damaged in any way or shows signs of leakage, contact your local representative immediately.
- Do not dispose of batteries in a fire. The batteries may explode.
- Handle, transport and recycle batteries in accordance with local representative.



WARNING

ALTHOUGH THE UPS HAS BEEN DESIGNED AND MANUFACTURED TO ENSURE PERSONAL SAFETY, IMPROPER USE CAN RESULT IN ELECTRICAL SHOCK OR FIRE. TO ENSURE SAFETY, OBSERVE THE FOLLOWING PRECAUTIONS:

- Turn off and unplug the UPS before cleaning it.
- Clean the UPS with a dry cloth. Do not use liquid or aerosol cleaners.
- Never block or insert any objects into the ventilation holes or other openings of the UPS.
- Do not place the UPS power cord where it might be damaged.

-  WARNING

- Disposal

	<p>Dispose of used battery according to the local instructions</p>
---	--

-

	<p>After unpacking save the packaging material ,recycle or dispose as law disposal</p>
---	--

-

	<p>This product not be disposed of as urban waste: The product's components must be disposed of separately as a WEEE. Any violations are punishable in accordance with the current regulations. Improper disposal of the product, or the improper use of the product or its parts, may be harmful to the environment and to human health. In the states of the European community or If is provided of local state disposal is possible return the product to the manufacturer, or ask a withdrawal when is purchasing an equivalent equipment.</p>
--	---

CONTENTS

IMPORTANT SAFETY INSTRUCTIONS.....	3
CONTENTS.....	7
1. ELECTROMAGNETIC COMPATIBILITY.....	9
2. INTRODUCTION.....	10
3. SYSTEM DESCRIPTION.....	11
3.1 Transient Voltage Surge Suppression (TVSS) and EMI/FRI Filters.....	11
3.2 Rectifier/Power Factor Correction (PFC) Circuit.....	12
3.3 Inverter.....	12
3.4 Battery Charger.....	12
3.5 DC-to-DC Converter.....	12
3.6 Battery.....	12
3.7 Dynamic Bypass.....	12
4. PRODUCT SPECIFICATION AND PERFORMANCES.....	13
4.1 Model Description.....	13
4.2 Product Specification and Performance.....	13
5. INSTALLATION.....	15
5.1 Unpacking and Inspection.....	15
5.2 Connect Input/Output Power.....	15
5.3 Operating procedure for connecting the long backup time model UPS with the external battery.....	19
5.4 Parallel operation.....	20
6. CONTROLS AND INDICATIONS.....	25
7. OPERATION.....	28
7.1 Operation Mode.....	28
7.2 Parallel Operation.....	29
7.3 Maintenance Bypass Operation Mode.....	29
8. BATTERY MAINTENANCE.....	31
9. NOTES FOR BATTERY DISPOSAL AND REPLACEMENT PROCEDURES.....	32

9.1 Battery Disposal	32
9.2 Battery Replacement Procedures	32
10. TROUBLE SHOOTING	33
10.1 Checking UPS status	33
10.2 Adjust the factors caused the problem	33
ANNEX A. RATED PARAMETERS SET ON LCD	38
ANNEX B. INTELLIGENT SLOT	40
ANNEX C. EPO	41

1. ELECTROMAGNETIC COMPATIBILITY

* Safety	
IEC/EN 62040-1	
* EMI	
Conducted Emission.....IEC/EN 62040-2	Category C3
Radiated Emission.....IEC/EN 62040-2	Category C3
*EMS	
ESD.....IEC/EN 61000-4-2	Level 4
RS.....IEC/EN 61000-4-3	Level 3
EFT.....IEC/EN 61000-4-4	Level 4
SURGE.....IEC/EN 61000-4-5	Level 4
Low Frequency Signals.....:IEC/EN 61000-2-2	
Warning: This is a product for commercial and industrial application in the second environment-installation restrictions or additional measures may be needed to prevent disturbances.	

NOTICE:

This is a product for restricted sales distribution to informed partners. Installation restrictions or additional measures may be needed to prevent radio interference.

Operated the UPS in an indoor environment only in an ambient temperature range of 0-40°C(32-104°F). Install it in a clean environment, free from moisture, flammable liquids, gases and corrosive substance.

This UPS contains no user-serviceable parts except the internal battery pack. The UPS on/off push buttons do not electrically isolate internal parts. Under no circumstance attempt to gain access internally, due to the risk of electric shock or burn.

Do not continue to use the UPS if the panel indications are not in accordance with these operating instructions or the UPS performance alters in use. Refer all fault to your dealer. Servicing of batteries should be performed or supervised by personnel knowledgeable of batteries and the precautions. Keep unauthorized personnel away from the batteries. Proper disposal of batteries is required. Refer to your local laws and regulations for disposal requirement.

DO NOT CONNECT equipment that could overload the UPS or demand DC current from the UPS, for example: electric drills, vacuum cleaners, laser printers, hair dryer or any appliance using half-wave rectification.

Storing magnetic media on top of the UPS may result in data loss or corruption.

Turn off and isolate the UPS before cleaning it. Use only a soft cloth, never liquid or aerosol cleaners.

2. INTRODUCTION

Congratulations on your choice of the UPS uninterruptible power system(UPS), the UPS comes in nominal power ratings of 10000VA and 20000VA. It is designed to provide conditioned power to microcomputers and other sensitive electronic equipment.

When it is generated, alternating current is clean and stable. However, during transmission and distribution it may be subject to voltage sags, spikes and complete power failure that may interrupt computer operations, cause data loss and even damage equipment. The UPS protects equipment from these disturbances.

The UPS is a compact, on-line UPS. An on-line UPS continuously conditions and regulates its output voltage, whether utility power is present or not. It supplies connected equipment with clean sinewave power. Sensitive electronic equipment operates best from sinewave power.

For ease of use, the UPS features a LCD display to indicate all information for UPS, and provide kinds of function buttons.

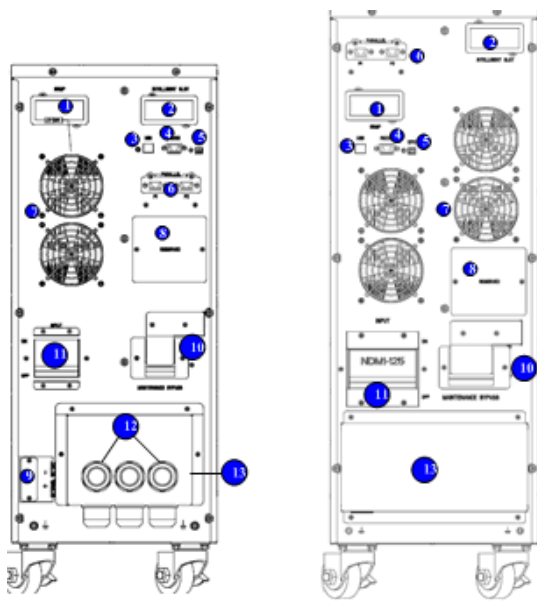

Model 10kVA-KS

Model 20kVA-KS

Fig 2. Rear View of 31 UPS

1. SNMP card slot
2. Dry contactor slot
3. USB port
4. RS232
5. EPO
6. Parallel ports
7. Fans
8. Reserved customer function
9. External battery connector. Optional for standard model.
10. Internal maintenance bypass
11. Input breaker
12. Cable entry protector
13. Terminal cover

3. SYSTEM DESCRIPTION

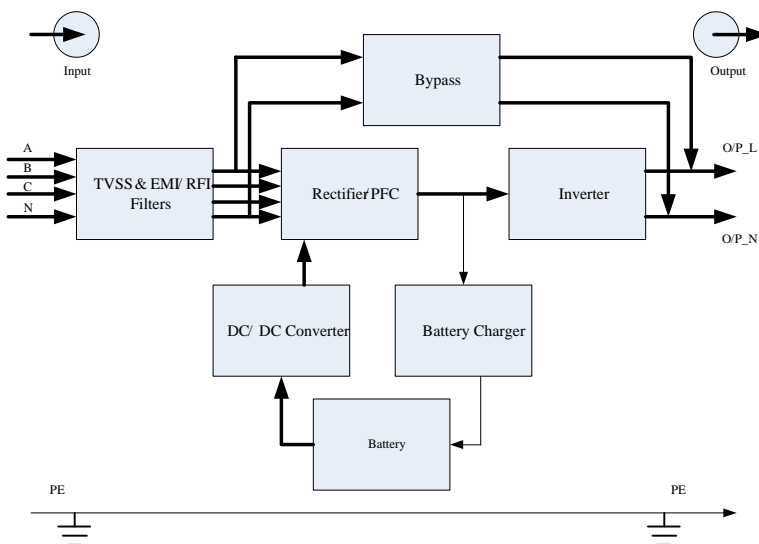

3.1 Transient Voltage Surge Suppression (TVSS) and EMI/FRI Filters

These UPS components provide surge protection and filter both electromagnetic interference (EMI) and radio frequency interference (RFI). They minimize any surge or

interference present in the utility line and keep the sensitive equipment protected.

3.2 Rectifier/Power Factor Correction (PFC) Circuit

In normal operation, the rectifier/power factor correction (PFC) circuit converts utility AC power to regulated DC power for use by the inverter while ensuring that the waveform of the input current used by the UPS is near ideal. Extracting this sinewave input current achieves two objects:

- The utility power is used as efficiency as possible by the UPS.
- The amount of distortion reflected on the utility is reduced.

This results in cleaner power being available to other devices in the building not being protected by the UPS.

3.3 Inverter

In normal operation, the inverter utilize the DC output of the power factor correction circuit and inverts it into precise, regulated sinewave AC power. Upon a utility power failure, the inverter receives its required energy from the battery through the DC-to-DC converter. In both modes of operation, the UPS inverter is on-line and continuously generating clean, precise, regulated AC output power.

3.4 Battery Charger

The battery charger utilizes energy from the utility power and precisely regulates it to continuously float charge the batteries. The batteries are being charged whenever the UPS is connected to utility power.

3.5 DC-to-DC Converter

The DC-to-DC converter utilizes energy from the battery system and raises the DC voltage to the optimum operating voltage for the inverter. The converter includes boost circuit which is also used as PFC.

3.6 Battery

To maintain battery design life, operate the UPS in an ambient temperature of 15-25°C.

3.7 Dynamic Bypass

The UPS provides an alternate path for utility power to the connected load in the

unlikely event of a UPS malfunction. Should the UPS have an overload, over temperature or any other failure condition, the UPS automatically transfers the connected load to bypass. Bypass operation is indicated by an audible alarm and illuminated amber Bypass LED. To manually transfer the connected load from the inverter to bypass, press the ON/OFF button or Manual Bypass button once.

NOTICE: *The bypass power path does NOT protect the connected equipment from disturbances in the utility supply.*

4. PRODUCT SPECIFICATION and PERFORMANCES

4.1 Model Description

This manual is applicable to the following models:

Model No.	Type
10K	Standard model (with internal batteries)
10K-KS	Long backup time
20K-KS	

4.2 Product Specification and Performance

1. General Specification

Model	10K	10K-KS	20K-KS
Power Rating	10KVA/9KW		20KVA/18KW
Frequency (Hz)	50/60		50/60
Input	Voltage	(304-478)VAC	
	Current	19A max	38A max
Battery	Voltage	192VDC	
	Current	60A max	120A max
Output	Voltage	220V/230V/240V	
	Current	45/43/42A	91/87/83A
	Recharge current	1A	5A
Dimension (WxDxH) mm	250*526*640		250*544*750
Weig (kg)	25		33

2. Electrical Performance

Input			
Model	Voltage	Frequency	Power Factor
10K/20K	Three-phase	40-70Hz	>0.95(Full load)

Output					
Voltage Regulation	Power Factor	Frequency tolerance.	Distortion	Overload capacity	Crest ratio
±1%	0.9 lag	±0.1% of normal	THD<1% Full load (Linear Load)	110% load: transfers to Bypass mode after 1 hour 130% load: transfers to Bypass mode after 1 minute 150% load :transfers to Bypass mode after 0.5 minute and shutdown the output after 1 minute	3:1 maximum

3. Operating Environment

Temperature	Humidity	Altitude	Storage temperature
0°C-40°C	<95%	<1000m	0°C-70°C

NOTICE: If the UPS is installed or used in a place where the altitude is above than **1000m**, the output power must be derated in use, please refer to the following:

Altitude (M)	1000	1500	2000	2500	3000	3500	4000	4500	5000
Derating Power	100%	95%	91%	86%	82%	78%	74%	70%	67%

5. INSTALLATION

The system should be installed and wired only by qualified electricians in accordance with applicable safety regulations.

NOTICE: *UPS operation in sustained temperature outside the range of 5°C (59°-77°F) reduces battery life.*

5.1 Unpacking and Inspection

- 1) Unpack the packaging and check the package contents. The shipping package contains:
 - 1 UPS
 - 1 user manual
 - 1 red Anderson connector and 1 black Anderson connector (10K)
 - 2 cable entry protector (10K)
 - 2 1 CD or licence for monitoring software UPSilon, setting software MTR .

- 2) Inspect the appearance of the UPS to see if there is any damage during transportation. Do not turn on the unit and notify the carrier and dealer immediately if there is any damage or lacking of some parts.

5.2 Connect Input/Output Power

1. Notes for installation

- 1) The UPS must be installed in a location with good ventilation, far away from water, inflammable gas and corrosive agents.
- 2) Ensure the air vents on the front and rear of the UPS are not blocked. Allow at least 0.5m of space on each side.
- 3) Condensation to water drops may occur if the UPS is unpacked in a very low temperature environment. In this case it is necessary to wait until the UPS is fully dried inside out before proceeding installation and use. Otherwise there are hazards of electric shock.

2. Installation

Installation and wiring must be performed in accordance with the local electric code and the following instructions by professional personnel.

It's suggested to install input protection breaker upstream the UPS. Here below the references:

ZY120-10K / KS: 40A-3P curve C 250Vac (on A-B-C) and 63A-2P curve C 250Vac on BYP-L/N
ZY120-20K-KS: 63A-3P curve C 250Vac (on A-B-C) and 125A-2P curve C 250Vac on BYP-L/N

For safety, please cut off the mains power switch before installation. Open the battery breaker for long backup time model ("L" model).

- 1) Open the terminal block cover located on the rear panel of the UPS, please refer to the appearance diagram.
- 2) For 10K UPS, it is recommended to select the UL1015 8AWG(10mm²) wire or other insulated wire which complies with AWG Standard for the UPS wirings.
- 3) For 20K UPS, it is recommended to select the UL1015 6AWG(25mm²) wire or other insulated wire which complies with AWG Standard for the UPS wirings.

NOTICE: Do not use the wall receptacle as the input power source for the UPS, as its rated current is less than the UPS's maximum input current. Otherwise the receptacle may be burned and destroyed. For the long backup time modes, make sure that the capacity of batteries is larger than 24AH to avoid over charging.

- 4) Connect the input and output wires to the corresponding input and output terminals according to the following diagram.

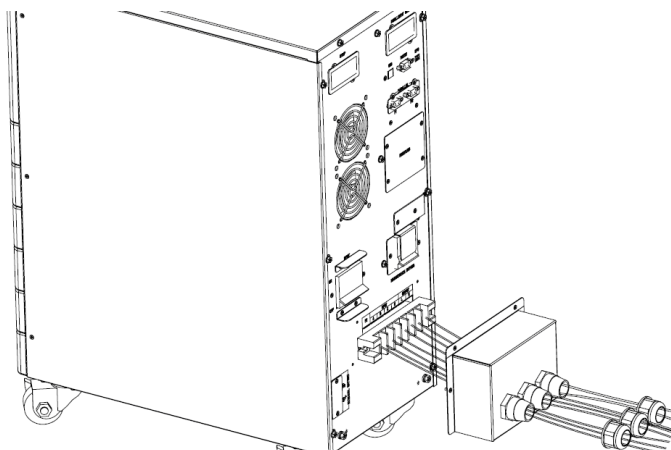

(a) Cables entry

BYP-L	INPUT				OUTPUT	
	A	B	C	N	L	N

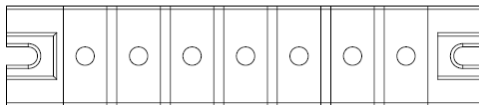

(b) Wiring connection

Fig 3. Input and Output Terminal Block Wiring Diagram of 3110L

Take out Anderson connector and make battery cables according to site's application shown as below:

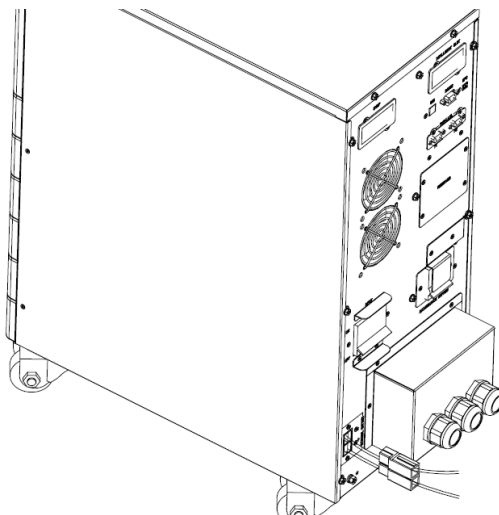

NOTICE: make sure that the red Anderson connector be connected to battery + and the black Anderson connector be connected to battery -, or else it may destroy UPS.

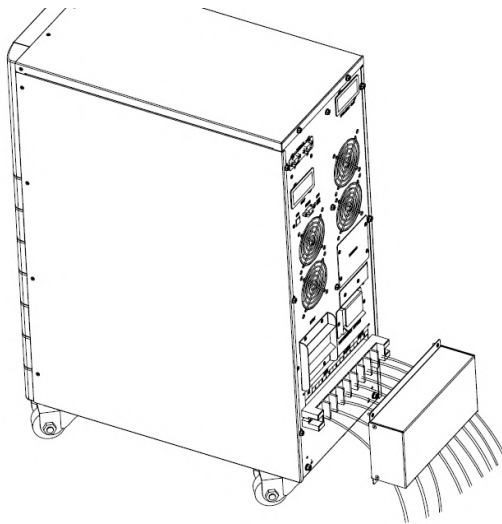

(a) Cables entry

BYP-L	INPUT				BATTERY		OUTPUT	
	A	B	C	N	+	-	L	N

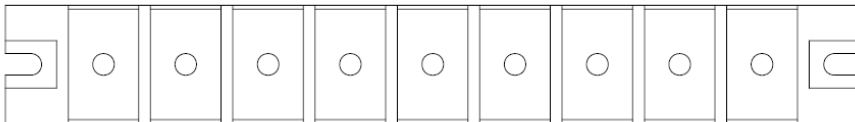

(b)Wiring connection

Fig 4. Input and Output Terminal Block Wiring Diagram of 3120L

NOTICE: You must make sure that the input and output wires and the input and output terminals are connected tightly.

- 5) The protective earth ground wire refers to the wire connection between the equipment which consumes electric equipment and the ground wire. The wire diameter of protective earth ground wire should be at least as above mentioned for each model and green wire or green wire with yellow ribbon wire is used.
- 6) After having completed the installation, make sure the wiring connection is correct.
- 7) Please install the output breaker between the output terminal and the load, and the breaker should with leakage current protective function if necessary.

- 8) To connect the load with the UPS, please turn off all the loads first, then perform the connection and finally turn on the loads one by one.
- 9) No matter the UPS is connected to the utility power or not, the output of the UPS may have electricity. The parts inside the unit may still have hazardous voltage after turning off the UPS. To make the UPS have no output, power off the UPS, and then disconnect the utility power supply.
- 10) Suggest charging the batteries for 8 hours before use. After connection, turn the input breaker in the “ON” position, the UPS will charge the batteries automatically. You can also use the UPS immediately without charging the batteries first, but the backup time may be less than the standard value.
- 11) If it is necessary to connect the inductive load such as a monitor or a laser printer to the UPS, the start-up power should be used for calculating the capacity of the UPS, as its start-up power consumption is too big when it is started.

5.3 Operating procedure for connecting the long backup time model

UPS with the external battery

1. The nominal DC voltage of external battery pack is 192VDC. Each battery pack consists of 16 pieces of 12V maintenance free batteries in series. To achieve longer backup time, it is possible to connect multi-battery packs, but the principle of “same voltage, same type” should be strictly followed.
2. The procedure of installing battery bank should be complied with strictly. Otherwise you may encounter the hazardous of electric shock.
 - 1) A DC breaker must be connected between the battery pack and the UPS. The capacity of breaker must be not less than the data specified in the general specification.
 - 2) Set the battery pack breaker in “OFF” position and connect the 16 pieces of batteries in series.
 - 3) You must connect the external battery cable to the battery first, if you connect the cable to the UPS first, you may encounter the hazardous of electric shock. The positive pole of the battery is connected to the UPS with red wire; the negative pole of the battery is connected to the UPS with black wire; the green and yellow ribbon wire is connected to the ground of the battery cabinet.
3. To complete the connection of the external battery cable into the UPS. Do not attempt to connect any loads to the UPS now. You should connect the input power

wire to the rig position first. And then set the breaker of the battery pack in the “ON” position. After that set the input breaker in the “ON” position. The UPS begins to charge the battery packs at the time.

5.4 Parallel operation

1. Brief introduction

As long as the UPS is equipped with parallel cables, up to 3 UPSs can be connected in parallel to realize output power sharing and power redundancy. The unit ID in paralleled system must be set to be different.

2. Parallel installation

- 1) Users need to opt two standard 15-pin communication cables which length is appropriate to be less than 3m.
 - 2) Strictly follow the stand-alone wiring requirement to perform the input wiring of each UPS.
 - 3) Connect the output wires of each UPS to an output breaker panel.
 - 4) Each UPS need an independent battery pack.
 - 5) Please refer to the wiring diagram in the next page, and opt suitable breaker.
- The requirement of the output wiring is as follows:
 - When the distance between the UPSs in parallel and the breaker panel is less than 20 meters, the difference between the wires of input & output of the UPSs is required to be less than 20%.
 - When the distance between the UPSs in parallel and the breaker panel is greater than 20 meters, the difference between the wires of input & output of the UPSs is required to be less than 10%.
 - In case of dual input connection the bypass line (BYP-L) of each UPS must be connected together

The wiring diagram are shown as follows:

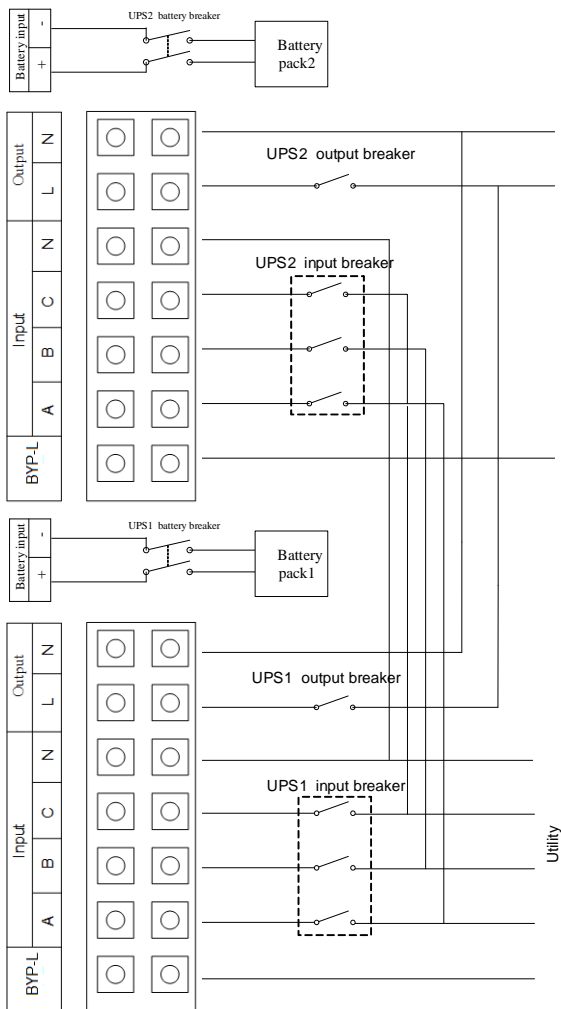

Fig.5 Wiring Diagram of 3110L

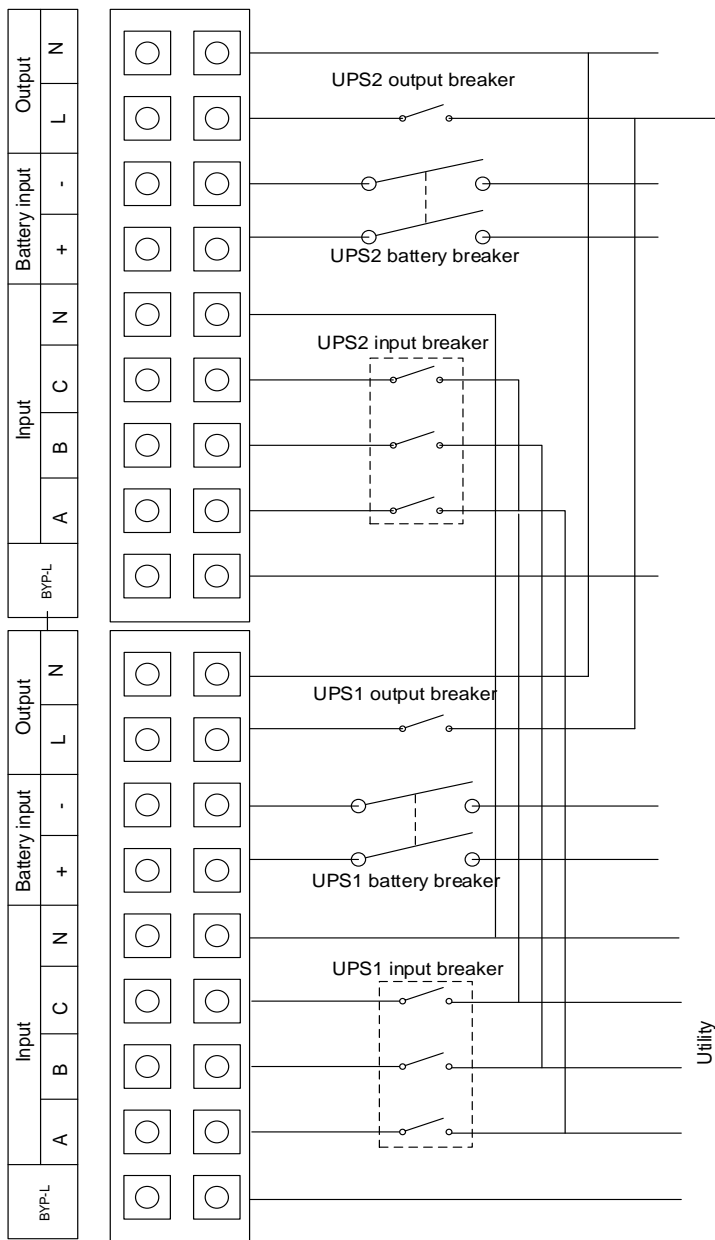

Fig.6Wiring Diagram of 3120L

3. Operation

- 1) To perform the general operation, follow the stand-alone operating requirement.
- 2) Startup: The units transfer to INV mode simultaneously as they start up sequentially in Line mode.
- 3) Shutdown: the units shut down sequentially in INV mode. When the last one completes the shutdown action, each unit will shut down the inverter simultaneously and transfer to Bypass mode.

It is easy to operate the equipment, with no previous training. You just need to read through this manual and operate according to the instructions in it.

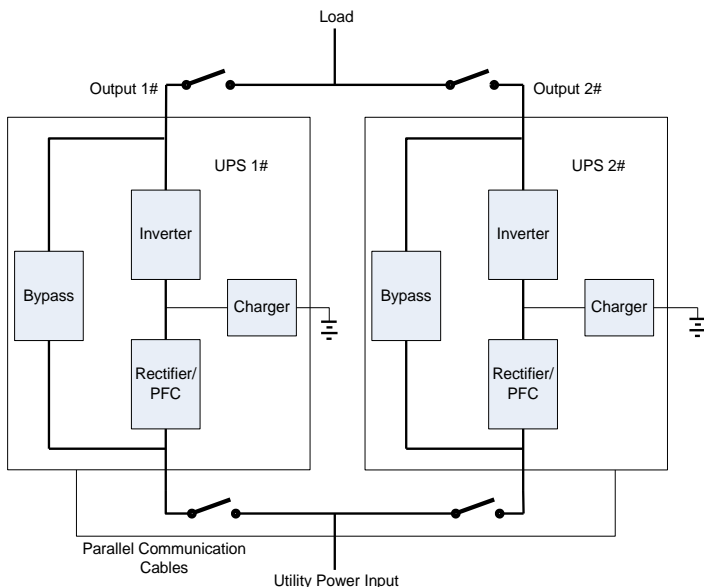

Fig 7. Parallel Installation Diagram

6. CONTROLS and INDICATIONS

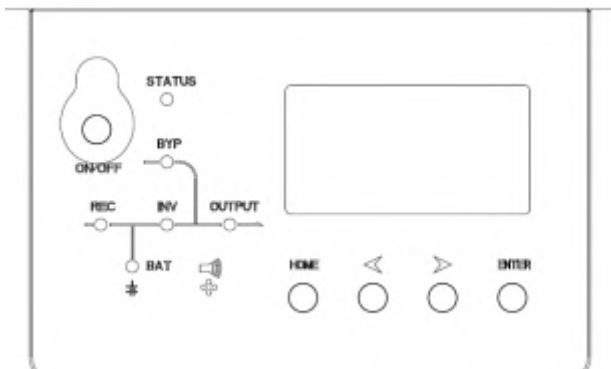

Fig.8 Display Panel

Description of Panel

Controls	Description
ON/OFF	<p>1.Press on/off to start inverter when rectifier is OK</p> <p>NOTE</p> <p><i>Not available when UPS is set in automatically start mode</i></p> <p>2.Press on/off directly when there is no main input, press again to start UPS</p> <p>3.Press on/off to shutdown inverter when UPS is in normal mode.</p> <p>4.Press on/off to shutdown UPS completely when UPS is in battery mode</p>
HOME	Back to main menu
◀ ▶	Left and rig
ENTER	Press to choose
Indicators	Description
STATUS	UPS status: green--normal mode, red--UPS is abnormal
REC	Rectifier indicator: green--rectifier is normal, green flicker--rectifier is starting, red--rectifier fault, red flicker--rectifier alarm, dark—rectifier is not working
INV	Inverter indicator: green--inverter is normal, green

	flicker—inverter is starting or tracking with bypass(ECO), red—inverter fault, and load is not on inverter, dark—inverter is not working
BYP	Bypass indicator: green—bypass is normal, dark—UPS is in normal mode and bypass is normal, red—bypass fault, red flicker—bypass alarm
BAT	Battery indicator: green—battery charge, green flicker—battery discharge, dark—battery is connected, red—battery fault, red flicker—battery alarm
OUTPUT	Output indicator: green—output is normal, red—output alarm

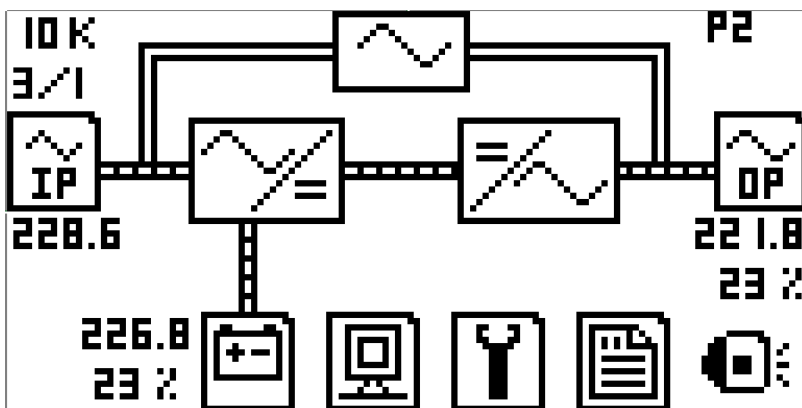









Fig 9. LCD Main Menu

Description of Main Menu

Display	Function	Submenu
	Input information	Main input: voltage, current, frequency, PF Bypass input: Voltage, current, frequency, PF
	Battery information	Battery: voltage, discharge current, battery status, battery temperature, capacity DCbus voltage
	Output information	Output information: Voltage, current, frequency, PF Load information:

Display	Function	Submenu
		Active power, apparent power, percent
	Status of UPS	Alarms, S-code, firmware version, system information
	Set and function	Set: language, contrast, communication set(SNT, Modbus), Modbus set Function: function 1(transfer to bypass/escape, fault clear, mute on/off), function 2(battery test, maintenance test, stop test)
	History log	/
10K 3/1	Rated capacity: 10KVA 3phase in/1 phase out: 3/1	10K-10kVA, 20K-20kVA
228.6	Input voltage	/
226.8 23 %	Battery voltage and capacity remained	/
221.8 23 %	Output voltage and load percent	/
P2	System working mode	S--single mode, E--ECO mode, P-parallel mode, 2-the unit ID is 2 in system, the units ID in parallel system should be different
	Mute on, mute off	

7. OPERATION

7.1 Operation Mode

1. Turn on the UPS in normal mode

- 1) After you make sure that the power supply connection is correct, and then close the battery breaker (this step only for long backup time model), after that close the input breaker. At this time the fans rotate and the UPS operates in Bypass mode.
- 2) After REC led is ready green, pressing the ON/OFF button continuously for more than 1 second, then choose ON to enter, the INV green led flickers.

NOTE

In some application, UPS is set to start automatically, this step is not need.

- 3) About 1 minute later, the UPS turn into normal Line mode. If the utility power is abnormal, the UPS will operate in Battery mode without output interruption of the UPS.

2. Turn on the UPS from battery without utility power

- 1) After you make sure that the breaker of the battery pack is in the "ON" position (this step only for long backup time model).
- 2) Press the ON/OFF button once to power on the LCD, then press ON/OFF button again, choose ON to enter.
- 3) A few seconds later, the UPS turns into Battery mode.

3. Turn off the UPS in normal mode

- 1) Press ON/OFF button in condition of normal mode, then choose OFF to transfer to bypass.
- 2) Open the input breaker to turn off utility power supply, then open the battery breaker to turn off UPS completely.

4. Turn off the UPS in Battery mode

- 1) To power off the UPS by pressing the ON/OFF button continuously for more than 1 second, then choose OFF.
- 2) When being powered off, the UPS will turn into No Output mode. Finally not any display is shown on the display panel and no voltage is available from the UPS output.

NOTICE: *Please turn off the connected loads before turning on the UPS and turn on the loads one by one after the UPS is working in INV mode. Turn off all of the connected loads before turning off the UPS.*

7.2 Parallel Operation

1. Parallel Machine Maintenance

This UPS system has parallel machine function, if you want to add single machine to parallel system, please follow operational process of joining new machine; if you must remove UPS, please follow operational processes of removing parallel machine.

2. How to install a new parallel UPS system:

- 1) Before installing a new parallel UPS system, user need to prepare the input and output wires, the output breaker, and the parallel cables.
- 2) Open the input and output breakers of each UPS. Connect the input wires, output wires and battery wires.
- 3) Connect each UPS one by one with the parallel cables.
- 4) Close the battery breakers and the input breakers of all of the UPSs in the parallel system in turn.
- 5) Turn on each UPS in turn and observe their display. Make sure that each UPS displays normal and all the UPSs transfer to the INV mode normally.

Notice: *close output 1# and 2# breakers as fig.5 to make sure that output of every UPS is shorted before starting UPS, or else parallel system will fail to start.*

3. How to remove a single UPS from the parallel system:

- 1) If you need to remove one UPS of the UPSs parallel system which is on normal running, press the ON/OFF button of the UPS that is confirmed to be removed continuously and the UPS will cut off its output immediately.
- 2) Turn off the input breaker, the external mains input breaker, the output breaker and the battery breaker.
- 3) Press the others UPSs's ON/OFF button. All of them transfer to the Bypass mode.
- 4) Remove the parallel cables of the UPS that need to be removed.
- 5) Press ON/OFF button of remained UPSs, then press YES to make the UPSs transfer to INV output.

7.3 Maintenance Bypass Operation Mode

Maintenance Bypass Mode operates on the condition that the inner power supply of the UPS is cut off and the load is supplied by the maintenance bypass.

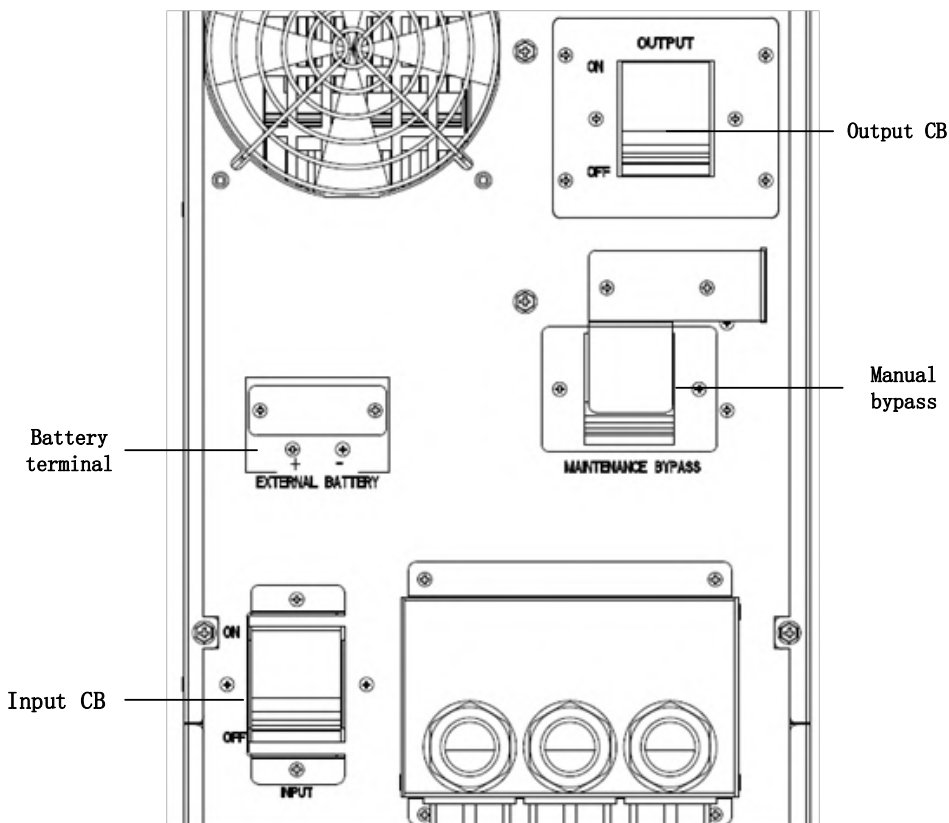

To transfer the UPS to Maintenance Mode, the following procedures should be followed.

1. Check the status before the Maintenance Mode.

Before transferring to the Maintenance Mode, the circuit breakers (CB) are in the following status: Input and Output are closed (in the on position); the Maintenance Bypass is open, as it is shown in the figure above;

2. Transfer to the Maintenance Mode for maintenance

(a) Enter the menu  -->function 1-->transfer to bypass and the system transfers to bypass.

Remove the cover that protects the Maintenance Bypass CB from misoperation and the UPS transfers to Bypass Mode with warning and wait until the LED indicator for bypass goes green

(b) Close the Maintenance Bypass CB;

(c) Open the CB for output and input and disconnect the battery(For the standard UPS type , pull out Battery terminal of positive and negative ; for the long run type UPS, open the battery CB).

3. Transfer back to Normal Mode

After the maintenance is finished, follow the procedures below to transfer the UPS to Normal Mode from Maintenance Bypass Mode.

(a) Connect the battery (For the standard UPS type, connect the Battery terminal of positive and negative; for the long run type UPS, close the battery CB)

(b) Close the CB for Input and Output.

(c) Open the CB for Maintenance Bypass and install the cover.

8. BATTERY MAINTENANCE

The UPS only requires minimal maintenance. The batteries used for standard models are value regulated, sealed lead-acid, maintenance free battery. When being connected to the utility power, whether the UPS is turned on or not, the UPS keeps charging the batteries and also offers the protective function of overcharging and over-discharging.

- The UPS should be charged once every 4 to 6 months if it has not been used for a long time.
- In the regions of hot climates, the battery should be charged and discharged every 2 months. The standard charging time should be at least 12 hours.
- Under normal conditions, the battery life lasts 3 to 5 years. In case if the battery is found in bad condition, earlier replacement should be made.
- Battery replacement should be performed by qualified personnel.
- Replace batteries with the same number and same type of batteries.
- Do not replace the battery individually. All the batteries should be replaced at the same time following the instructions of the battery supplier.

9. NOTES for BATTERY DISPOSAL and REPLACEMENT PROCEDURES

9.1 Battery Disposal

- 1) Before disposing of batteries, remove jewelry, watches and other metal objects.
- 2) Use rubber gloves and boots, use tools with insulated handles.
- 3) If it is necessary to replace any connection cables, please purchase the original materials from the authorized distributors or service centers, so as to avoid overheat or spark resulting in fire due to insufficient capacity.
- 4) Do not dispose of batteries or battery packs in a fire. The batteries may explode.
- 5) Do not open or mutilate batteries, released electrolyte is highly poisonous and harmful to the skin and eyes.
- 6) Do not short the positive and negative of the battery electrode, otherwise, it may result in electric shock or fire.
- 7) Make sure that there is no voltage before touching the batteries. The battery circuit is not isolated from the input potential circuit. There may be hazardous voltage between the battery terminals and the ground.
- 8) Even though the input breaker is disconnected, the components inside the UPS are still connected with the batteries, and there are potential hazardous voltages. Therefore, before any maintenance and repairs work is carried out, switch off the breaker of the battery pack or disconnect the jumper wire of connecting between the batteries.
- 9) Batteries contain hazardous voltage and current. Battery maintenance such as the battery replacement must be carried out by qualified personnel who are knowledgeable about batteries. No other persons should handle the batteries

9.2 Battery Replacement Procedures

- 1) Press ON/OFF button to transfer to bypass mode
- 2) Switch the maintenance switch from UPS to Manual BYP
- 3) Remove both side covers from the UPS.
- 4) Disconnect the battery wires one by one.
- 5) Remove metal bars which are used to fasten batteries.
- 6) Replace batteries one by one.
- 7) Screw metal bars back to UPS.

- 8) Connect the battery wires one by one. Take care of electrical shock while connecting the last wire.

10. TROUBLE SHOOTING

This section describes checking the UPS's status. This section also indicates various UPS symptoms a user may encounter and provides a troubleshooting guide in the event the UPS develops a problem. Use the following information to determine whether external factors caused the problem and how to remedy the situation.

10.1 Checking UPS status

It is recommended that checking the UPS operation status every six months.

- Check whether the UPS is faulty: Is the Fault Indicator on? Is the UPS sounding an alarm?
- Check whether the UPS is operating in Bypass mode. Normally, the UPS operates in Normal Mode. If it is operating in Bypass Mode, stop and contact your local representative, or Channel Support.
- Check whether the battery is discharging. When the utility input is normal, the battery should not discharge. If the UPS is operating in Battery Mode, stop and contact your local representative, or Channel Support.

10.2 Adjust the factors caused the problem



When the fault indicator is on, press  button to get S-code. So, S1 indicates status and A0-A5 indicates the exact fault of UPS, S-code list is shown as follow:

Description of S-Code

Seq.		Items	0	1	Solution
1	A0	1 Synchronous Fault	Sync	Not sync.	Check whether bypass voltage/frequency is normal
2		2 Main Input Fault	OK	Fault	Check whether input is normal
3		3 REC Fault	OK	Fault	REC over temperature, bus over voltage, input current unbalance, soft start fail
4		4 INV Fault	OK	Fault	INV over temperature, INV IGBT broken, INV relay fault

Seq.		Items	0	1	Solution	
5		Reserved				
6		Reserved				
7		Reserved				
8		Reserved				
9		Reserved				
10		Reserved				
11		Reserved				
12		Reserved				
13		Input phase A over current	OK	Fault	Check if rectifier IGBT is broken, DC bus is shorted, or IGBT drivers are lost, input voltage display is wrong	
14		Input phase B over current	OK	Fault		
15		Input phase C over current	OK	Fault		
16		Output voltage Fault	OK	Fault	Check if inverter IGBT is broken, IGBT drivers are lost	
17	A1	Reserved				
18		Reserved				
19		Reserved				
20		Reserved				
21		Reserved				
22		Reserved				
23		Reserved				
24		Reserved				
25		9	Input voltage Fault	OK	Fault	Input voltage out of range
26		10	Input Frequency Fault	OK	Fault	Input frequency out of range
27		11	Input Sequence Fault	OK	Fault	Input sequence is wrong, check whether input wires connection is ok.
28		12	REC soft-start	OK	Fault	Check whether rectifier SCR is



Seq.		Items	0	1	Solution
		Fault			broken, or SCR drivers are lost.
29		13 Reserved			
30		14 Reserved			
31		15 REC over temperature	OK	Fault	Check if the environmental temperature is over 40, if rectifier IGBTs is properly installed.
32		16 Positive bus over voltage	OK	Fault	UPS requires service
33	A2	1 Negative bus over voltage	OK	Fault	UPS requires service
34		2 Fan Fault	OK	Fault	At least one of fans fail.
35		3 Reserved			
36		4 Reserved			
37		5 Positive bus under voltage	OK	Fault	UPS requires service
38		6 Negative bus under voltage	OK	Fault	UPS requires service
39		7 Battery reversed	OK	Fault	Check if the battery wires connection is OK
40		8 Reserved			
41		9 Reserved			
42		10 Reserved			
43		11 Reserved			
44		12 Reserved			
45		13 Battery over temperature	OK	Fault	Check if environmental temp is too high or batteries life is over
46		14 Reserved			
47		15 Reserved			
48		16 Reserved			
49	A3	1 Battery voltage low	OK	Fault	
50		2 Reserved			

Seq.		Items	0	1	Solution
51		3 Battery EOD	OK	Fault	
52		4 Reserved			
53		5 Reserved			
54		6 Reserved			
55		7 BYP voltage Fault	OK	Fault	Check if bypass input voltage is normal
56		8 Bypass SCR or relay fault	OK	Fault	UPS requires service.
57		9 Reserved			
58		10 Reserved			
59		11 BYP frequency over track range	OK	Fault	Check if bypass input frequency is abnormal
60		12 Reserved			
61		13 Reserved			
62		14 Over load time out	OK	Fault	
63		15 Reserved			
64		16 Reserved			
65		1 Manual shutdown	normal	shutdo wn	
66		2 INV protect	OK	Fault	
67		3 Transfer times limit in one hour	OK	Fault	Transfer times between inverter and bypass is over 5 times in one hour
68		4 Reserved			
69	A4	5 Reserved			
70		6 Reserved			
71		7 Reserved			
72		8 INV over temperature Fault	OK	Fault	Check if environmental temp is over 40°C, or fans are abnormal
73		9 Reserved			
74		10 Reserved			

Seq.		Items	0	1	Solution
75		11 Over load	OK	Over load	Check load level indicator and remove non-essential load. Recalculate the load and remove number of loads connected to UPS.
76		12 INV relay or fuse Fault	OK	Fault	Check if inverter relay is shorted or opened.
77		13 Reserved			
78		14 Parallel connection fault	OK	Fault	Check whether parallel connection cable disconnect.
79		15 Reserved			
80		16 Reserved			
81		1 Reserved			
82		2 Output shorted	OK	Fault	Shutdown UPS and open output breaker, check if load is effective or short internally, check if output connector is shorted.
83		3 Battery test	None	OK	2--Fault
84		4 Battery maintenance	None	OK	2--Fault
85		5 Reserved			
86	A5	6 Reserved			
87		7 Reserved			
88		8 Reserved			
89		9 Reserved			
90		10 Reserved			
91		11 Reserved			
92		12 Reserved			
93		13 Reserved			
94		14 Reserved			
95		15 Reserved			
96		16 Reserved			

Annex A. Rated Parameters Set on LCD



1. Power on LCD



2. Press button   together for 3 seconds, enters in rated setting menu as below

 	RATE SET	
IP	V(LN) 220	
OP	V(LN) 220	
FREQ	HZ 50	

3. Press button "ENTER" to activate setting function as below. Shadow means the current parameter can be set now.



 	RATE SET	
IP	V(LN) 220	230
OP	V(LN) 220	220
FREQ	HZ 50	50

4. Input voltage setting is activated. Press   to select the rated input voltage. The voltages are available for customer such as: 110V, 120V, 127V, 200V, 208V, 220V, 230V, 240V.

5. Press "ENTER" button to confirm input voltage selection and activate output voltage setting menu as below. Press   to select the rated output voltage. Output voltages are available for customer such as: 110V, 120V, 127V, 200V, 208V, 220V, 230V, 240V.

RATE SET			
IP	V(LN)	230	230
OP	V(LN)	220	230
FREQ	HZ	50	50

6. Press “ENTER” button to confirm output voltage selection and activate frequency setting.

Press   to select the rated frequency. 50Hz and 60Hz are available for selection.

RATE SET			
IP	V(LN)	230	230
OP	V(LN)	230	230
FREQ	HZ	50	50 60

7. Press “ENTER” button to confirm frequency selection, and the current parameters are shown on LCD as below

RATE SET			
IP	V(LN)	230	
OP	V(LN)	230	
FREQ	HZ	60	

8. Shutdown UPS completely and restart UPS to activate the setting. Enter in  and enter in system information to check if the rated setting has been activated as below

« RATE INFO	
I/P	230V/60Hz
OP	230V/60Hz
Power	06000VA

Annex B. Intelligent slot

Max output current for intelligent slot is 1A/24V.

The functions of intelligent slot are listed as fig.7:

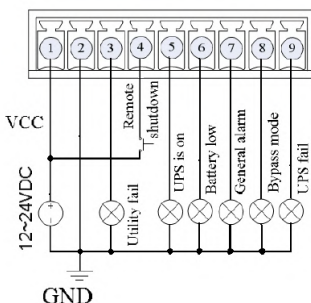

(b)Phoenix Terminal

Description of contacts:

Output contact meaning	Pins	Contact status
Utility fail	1-3	Opened when mains failure occurs Closed when mains is OK
Normal mode	1-5	Opened when inverter OFF Closed when inverter ON
Battery low	1-6	Opened when alarm occurs Closed without alarm
General alarm	1-7	Opened when alarm occurs Closed without alarm
Bypass mode	1-8	Opened when UPS not in bypass mode Closed when UPS in bypass mode
UPS fail	1-9	Opened when alarm occurs Closed without alarm
UPS Shutdown	2-4	Inverter switch off when voltage present (12-24Vdc) between pin 2(-) and 4 (+)

WARNING: Dry-contact card is not plug & play. Before insert the card insure to put the UPS in maintenance bypass.

Annex C. EPO

EPO (emergency power off) is optional function to shutdown UPS completely at emergency condition. This function can be activated through a remote contact provided by the user.

It requires opening NC contact.

For remote function is necessary to remove the bridge and connect the terminals to the remote NC auxiliary contact of emergency switch.

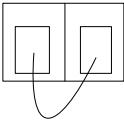

EPO terminals

